

DTU



Upgrading a 3D-Printed Gripper for Enhanced Robotic Handling

41739 - Experimental plastic and metal processing technology

Marc Lahn Trustrup - s205254

Jasmin Mandix Madsen - s205266

Ožbej Vidmar - s243499

Oscar Emil Kingelin Larsen - s205250



Brief summary of the project

- Collaboration with DALSA
- Design of gripper attachment on a robotic arm
- Used to transport samples from one machine to another
- A need for automation
- Several problems with existing gripper

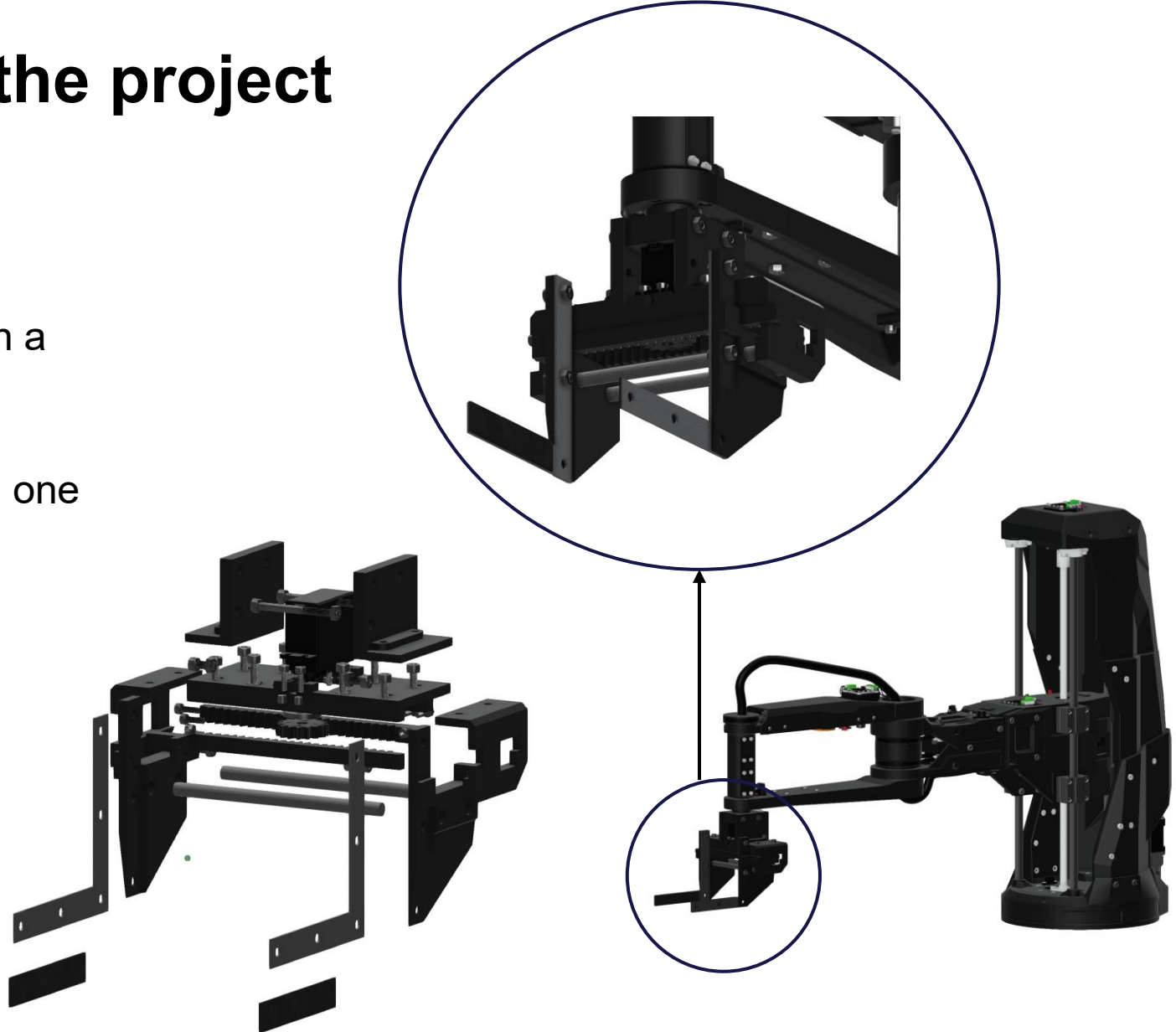

Methodology of the project

General methods

- Brainstorming
- Stakeholder interviews
- Lab observations
- Rapid prototyping

Experimental methods

- Gripping test
- Deflection test

Analytical method

- Force analysis
 - Deflection
 - Stress

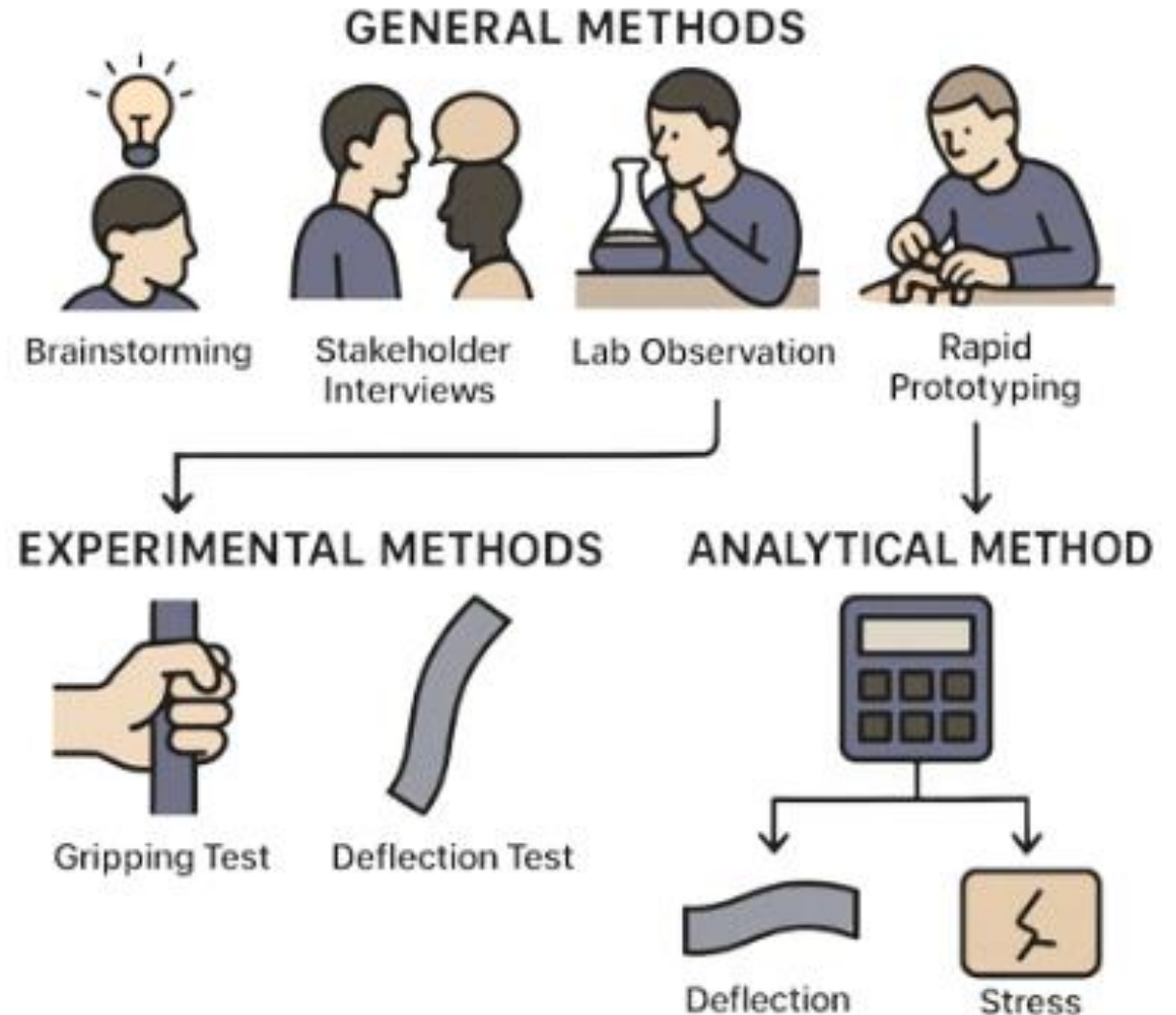

Final iteration Base

- Extended design
- Increased thickness
- Supports added
- Metal rods (new since last week)

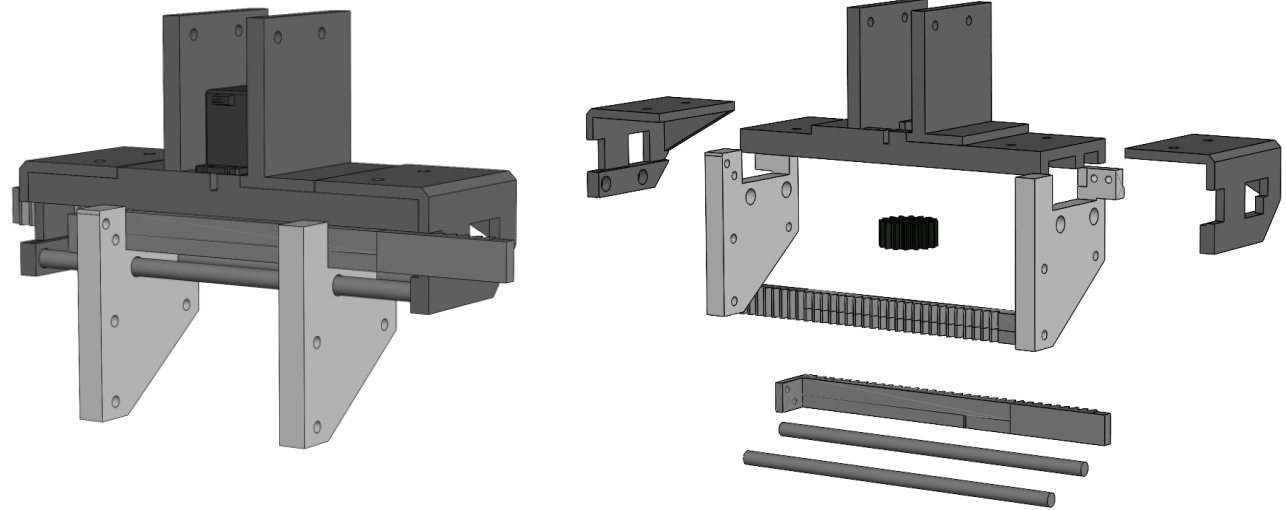

Final iteration gripper

Three types of grippers:

2.2

- Four contact points (tips)
- 10mm thickness

3.1

- Improved version
- Hook
- 8mm thickness

3.3

- No structural beam
- 5mm thickness

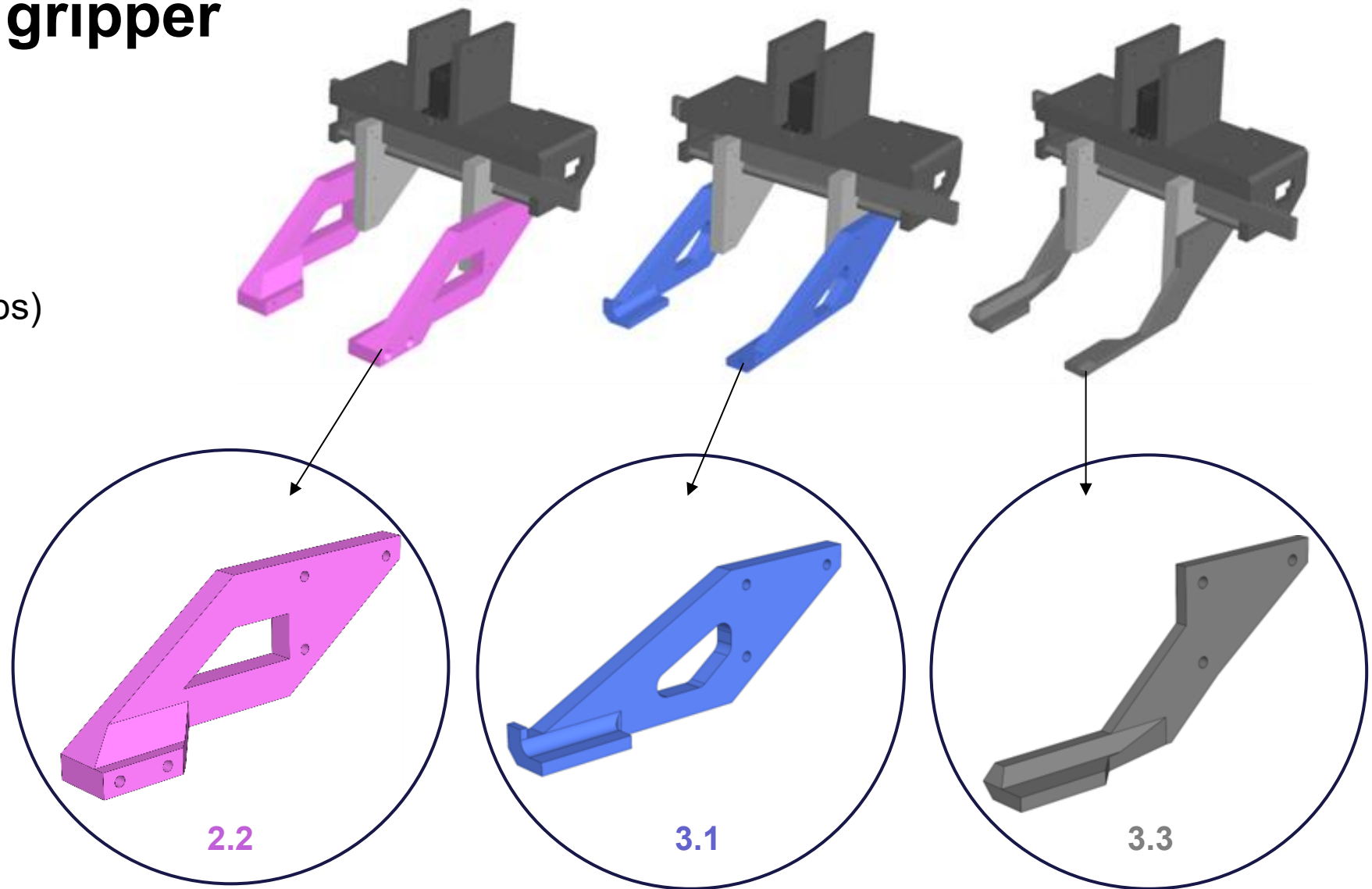

1. Experiment: Gripping test

Test sequence was performed for each gripper and each plate type

1. Grip the empty plate
2. Apply the maximum load in the center
3. Apply half the maximum weight at either end
4. Apply a quarter of the total weight in each corner

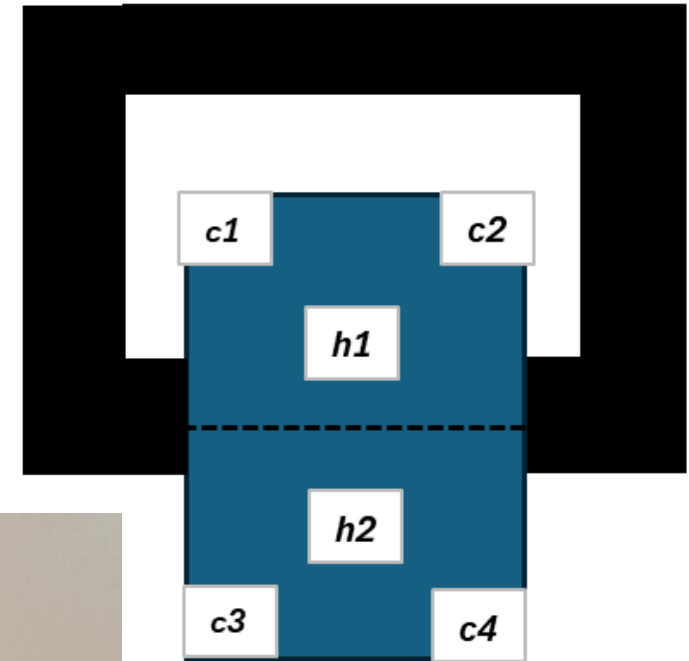
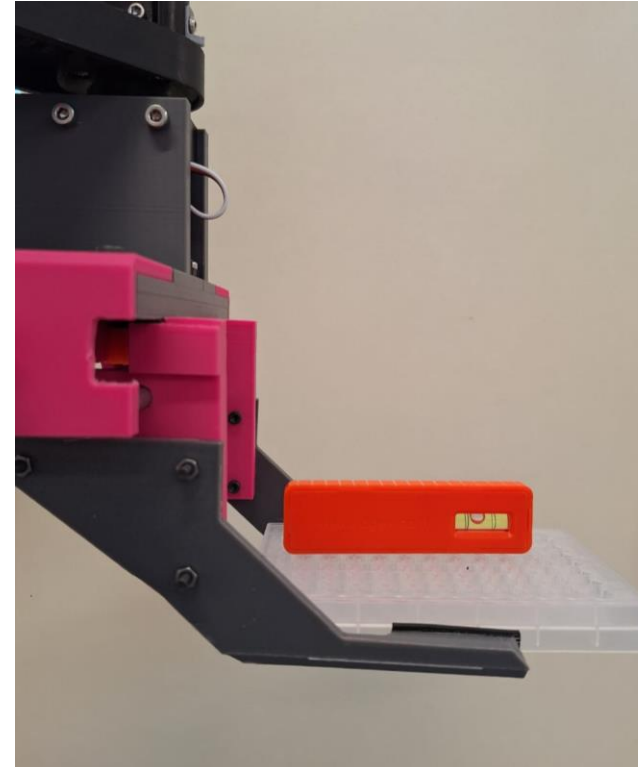

Results from the gripping test

Succes criteria:
Able to hold for >30 seconds, 3 times

Test gripper 3.1								
	Without weights	80 g	40 g, h1	40 g, h2	20 g, c1	20 g, c2	20 g, c3	20 g, c4
Sample plate A								
	Without weights	355 g	177 g, h1	177g,2	88 g, c1	88 g, c2	88 g, c3	88 g, c4
Sample plate B								
Test gripper 2.2								
	Without weights	80 g	40 g, h1	40 g, h2	20 g, c1	20 g, c2	20 g, c3	20 g, c4
Sample plate A								
	Without weights	355 g	177 g, h1	177g,2	88 g, c1	88 g, c2	88 g, c3	88 g, c4
Sample plate B								
Test gripper 3.3								
	Without weights	80 g	40 g, h1	40 g, h2	20 g, c1	20 g, c2	20 g, c3	20 g, c4
Sample plate A								
	Without weights	355 g	177 g, h1	177g,2	88 g, c1	88 g, c2	88 g, c3	88 g, c4
Sample plate B								

- Pass
 - Fail

Common weakness.

- Uneven force distribution
- Cause: Likely deflection
- Pressure is applied in the back rather than in front

2. Experiment: Deflection test

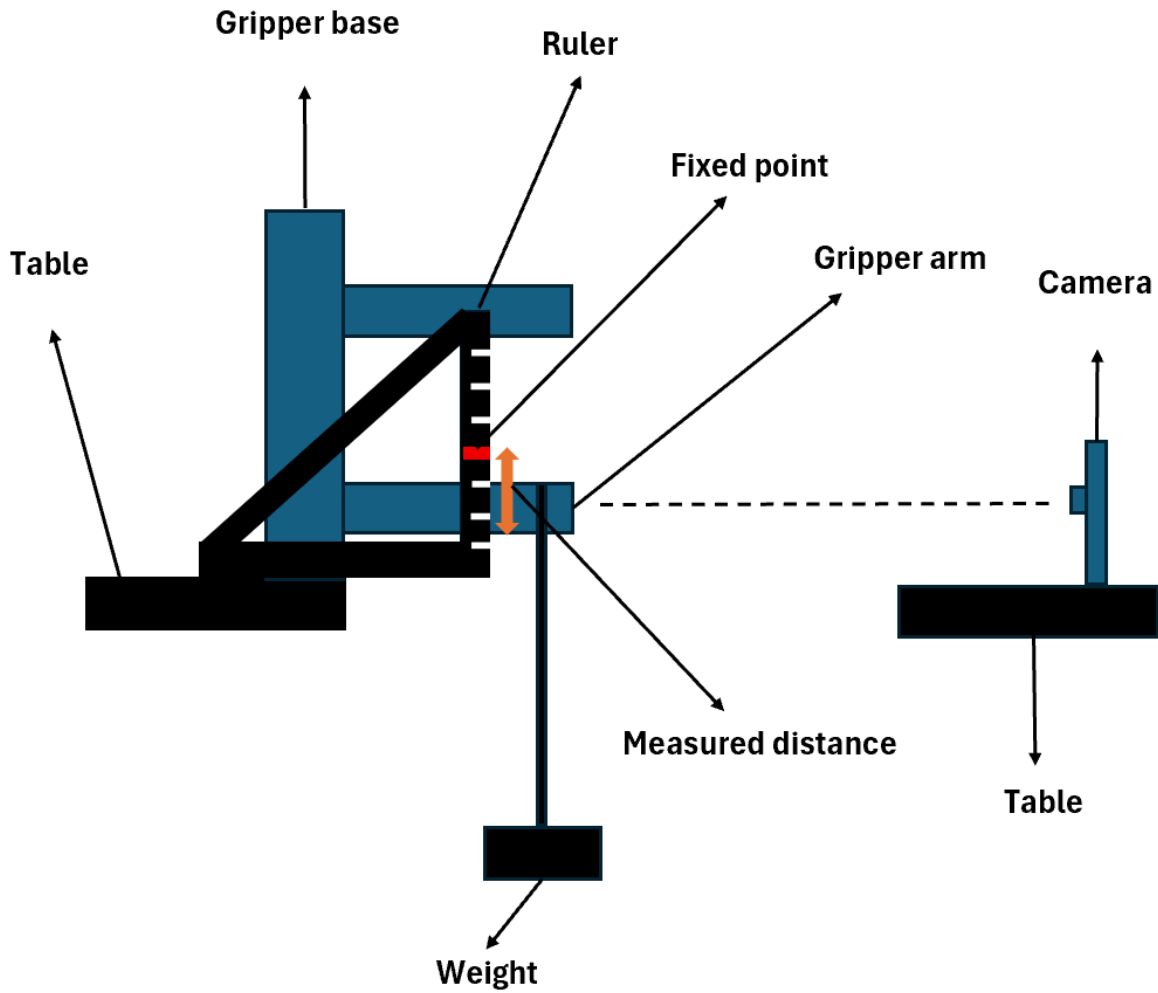

Results for the deflection test

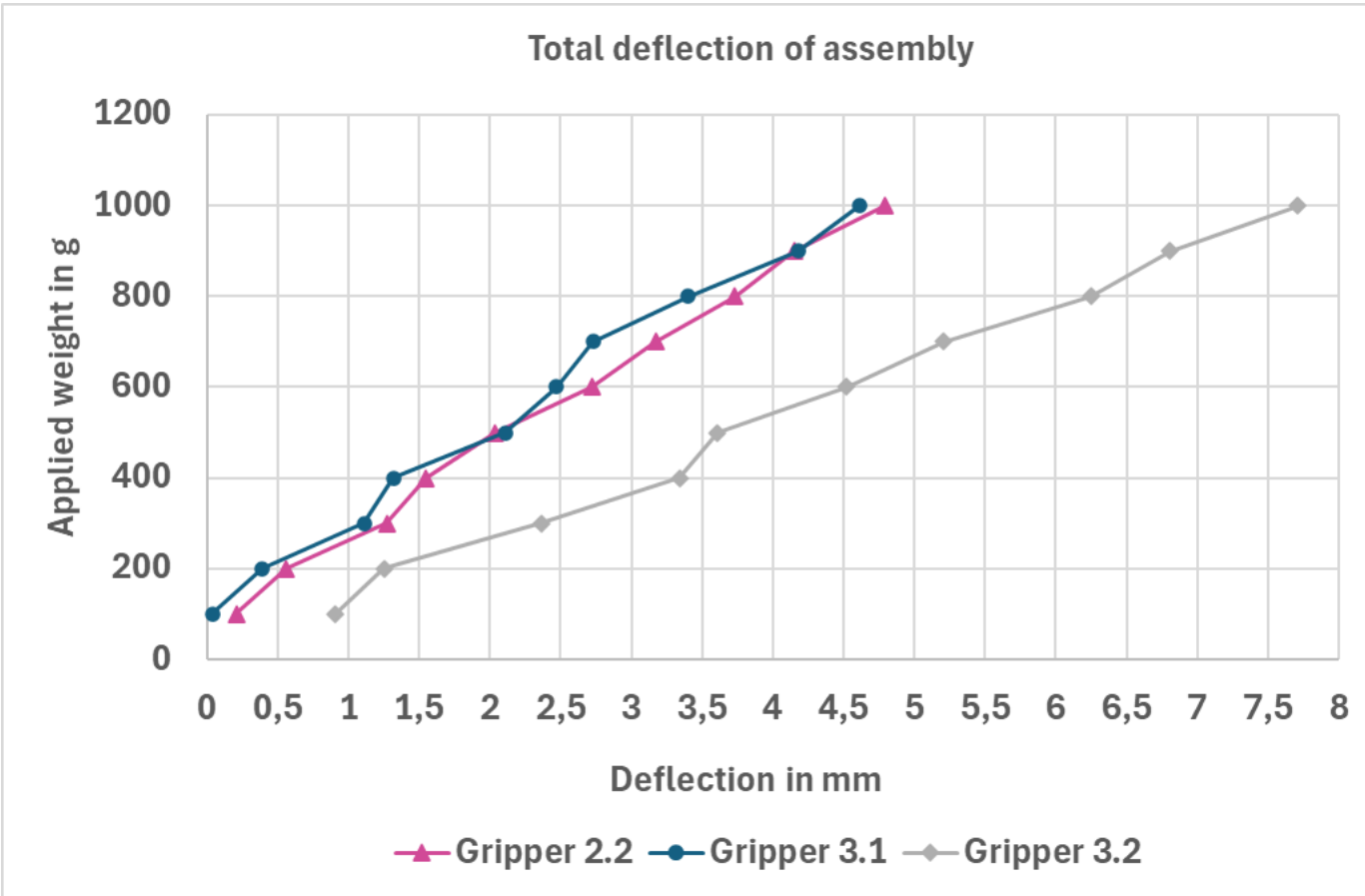

Gripper 3.1

- lowest amount of deflection under applied load
- maximal deflection of 4,6 mm at 1000 g.

Gripper 2.2

- The curve for the assembly with gripper 2.2 closely follows the curve of gripper 3.1,

Gripper 3.2

- Largest deflection
- maximum deflection of 7,7 mm at 1000 g.

The deflection not only occurs on the grippers but also from the whole base and assembly

Simulations of all iterations

- **Iteration 2.0** had high **deflection** of **1.4 mm** and stress at sharp corners
- **2.1** added support beam → reduced **deflection to 0.7 mm**
- **2.2** shortened length + fillets → improved stiffness
- **2.3** tapered tip + short → only **0.1 mm deflection**
- **2.4** made longer + 10 mm thick → **0.09 mm deflection** but too bulky
- 3rd iteration (**3.1**) balanced reach + **8 mm thickness** → **0.5 mm deflection**
- Tested **5 mm** in 3.2 → **1.4 mm deflection**

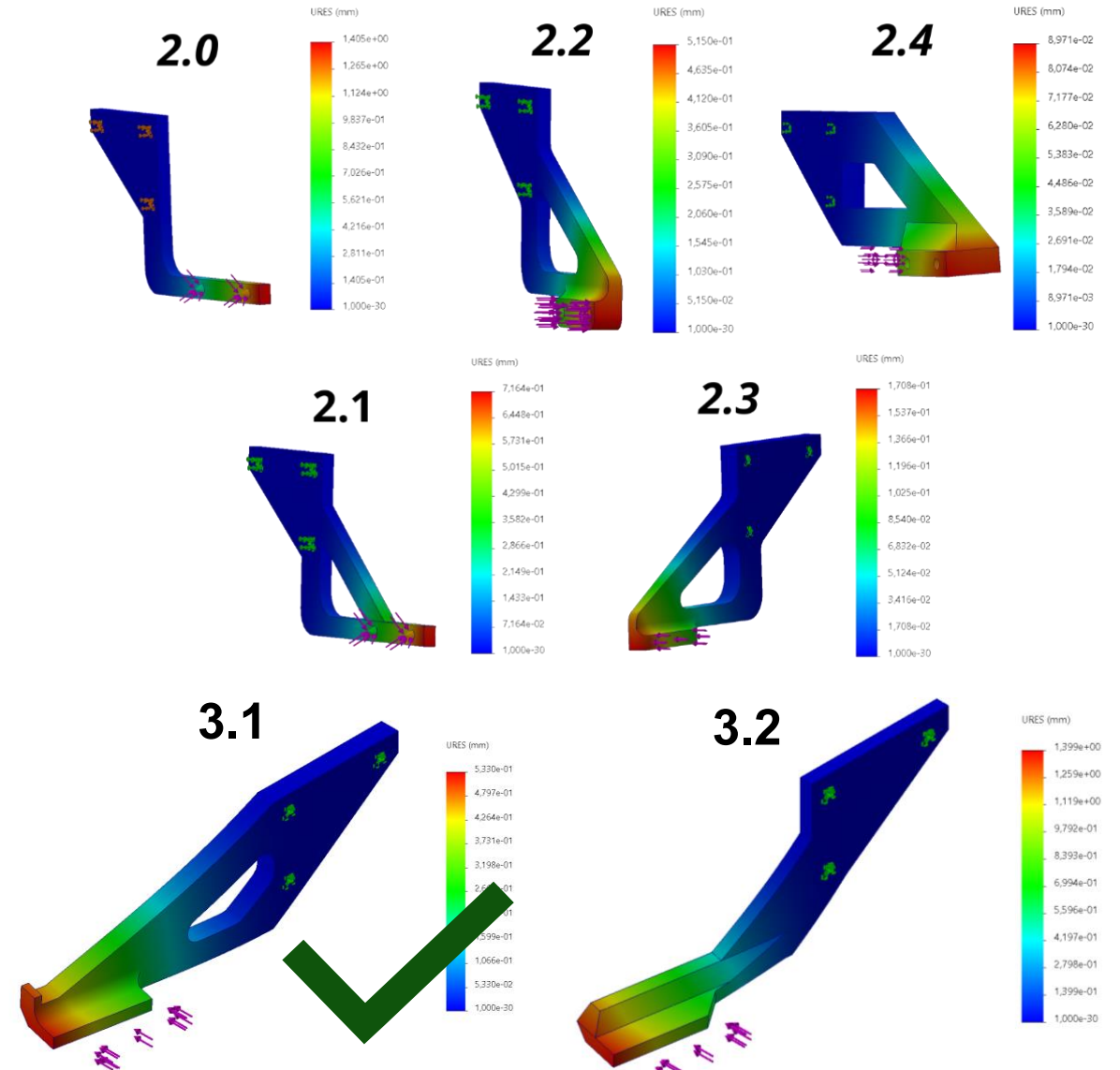

Comparison of experimental and simulation data

- Simulations showed much lower deflection than physical tests
- Differences for 6 N
 - 2.2: 1.9 mm
 - 3.1: 2.5 mm
 - 3.2: 3.1 mm
- Real deflection likely **comes from the full assembly**, not just the gripper
 - Large deflection observed in tests is likely **caused by base flexibility**
- Main possible causes:
 - **Loose tolerances** from 3D printing/sanding → unwanted play
 - **Weak parts** in base/gear design → **needs reinforcement**

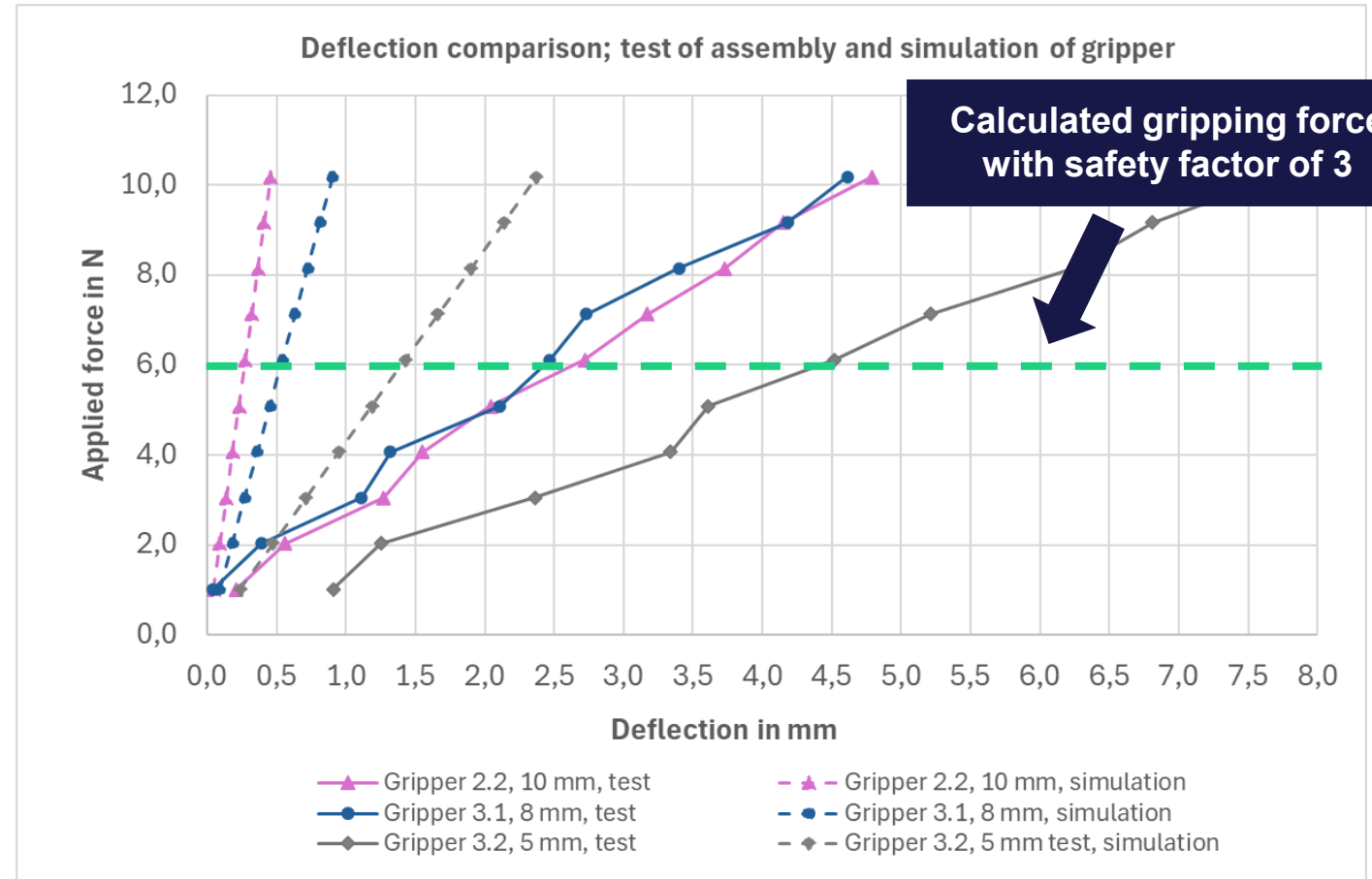

Machine compatibility

Simulation deflection (6N) in mm	Test deflection (6N) in mm		Mantice	Plate hotel	Perkin Elmer	Suction cup holder	Plate rack	Sealing machine	BioTek plate washer	Multi drop	Compatibilty %
0,27	2,72	Gripper 2.4	Yes	No	No	Yes	Yes	Yes	No	No	50%
0,54	2,47	Gripper 3.1	Yes	Yes	Yes	Yes	Yes	Yes	Yes	Yes	100%
1,43	4,52	Gripper 3.2	Yes	No	Yes	Yes	Yes	Yes	Yes	Yes	87,5%

Gripper 3.1 is the best choice

- Still **problems with deflection**
- Tolerances for the robot arm is **lower than 1 mm** is needed

Proposals for future work

- **Gripper 3.1 can be used if:**
 - **Redesign of base and gears** is strengend (make it more stable and do simulation)
- **Can be improved with other materials** to lower weight and make parts thinner with less displacements
 - Introduce **metal components** (Al to keep low weigth, thinner and less displacement)
 - Look into **3D printable material with carbon fibers**

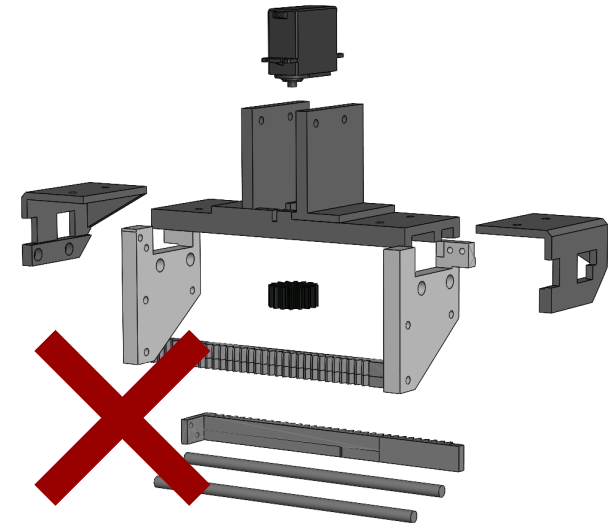
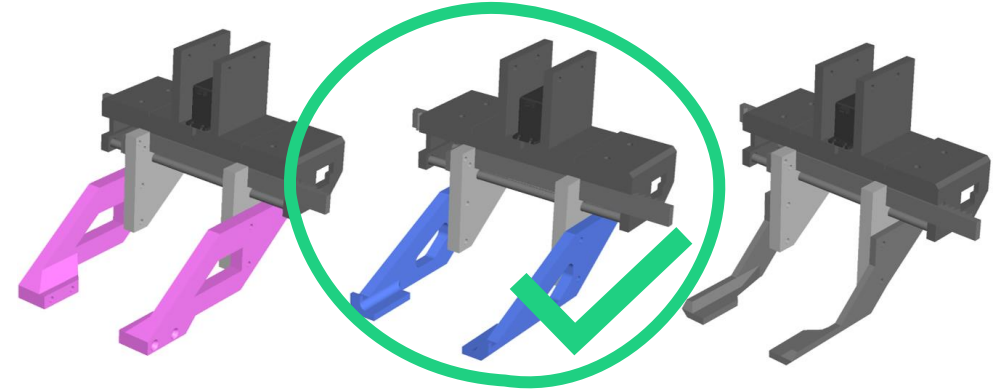

Thanks for listening 😊

DTU

